

TECNOLOGIA

MODULAR

BY MEDELINOX



SOLUTIONS

Discover our range of high-quality solutions. Intelligent designs.

ESTRUCTURAS METALICAS

Desde naves industriales hasta cabinas tecnicas cerradas.



RESTOBAR DESIGN

Diseño de barras y cocinas modulares.



MOBILIARIO

Mobiliario metalico sanitario.



ESTRUCTURAS METALICAS

Diseño y fabricacion de estructuras metalicas modulares.

Contamos con la capacidad productiva para diseñar y luego fabricar naves industriales, módulos habitacionales y módulos productivos, enfocados en el objetivo de nuestros clientes. Conoce todas nuestras soluciones estandarizadas para optimizar costos y esfuerzos.



NAVES INDUSTRIALES



SMART HOUSE

Una combinación de conocimientos y habilidades en diversos campos que puede mejorar el rendimiento.

A combination of knowledge and skills in various fields that can improve performance.



E-BOX



NAVES INDUSTRIALES

Enviamos estructura con manuales de armado para optimizar costos y logistica.

We send the structure with assembly manuals to optimize costs and logistics.



DOS AGUAS STEEL
FRAMING

HASTA 12M DE ANCHO



UN AGUA PERFIL "C"
RETICULADO

HASTA 15M DE ANCHO



DOS AGUAS PERFIL "C"
RETICULADO

HASTA 30M DE ANCHO



DOS AGUAS APLINO
PERFIL "C" RETICULADO

HASTA 15M DE ANCHO



FACHADAS COMERCIALES

Diseño y transformación de fachadas.
Genera impacto.

Chapa negra

Adecuaciones de fachadas comerciales con estructuras metálicas.



Chapa horizontal

Diseño y disposición de elementos alineados con el objetivo comercial.



Corte laser

Flexibilidad de componentes y combinación para lograr impacto visual.



SMART HOUSE

Construcción en seco, estructuras robustas con terminaciones de calidad. Solicite un presupuesto de acuerdo a m2.

Diseño y construcción de módulos de acuerdo a su necesidad.

MODULAR



Design and construction of modules according to your needs.



E - BOX

Estructuras estandarizadas aplicadas a determinados objetivos.

Standardized structures applied to specific objectives.



Estandar

Modulo apto para diversos objetivos habituales.



Sanitario

Modulo aplicable a funciones que requieran cuidado sanitario.



Cabina cerrada

Cabina de trabajo especialmente diseñada para requerimientos particulares de industrias específicas.
ALIMENTOS, LABORATORIOS, HOSPITALES, FARMACIAS.



APLICACIONES

Medidas estimadas.

Alto 2.3 M

Ancho 2 y 4 M

Profundidad 1 M

Equipamiento opcional segun requerimiento.

Estimated dimensions.

Height: 2.3 m

Width: 2 and 4 m

Depth: 1 m

Optional equipment available upon request.



COCCION



NEGOCIO



GIMNASIO
DEPORTIVO



CONSTRUCCION



APLICACIONES



Solucion eficiente

Espacio dinamico y flexible para una funciones especificas. Diseño inteligente.



Solucion segura

espacio totalmente seguro con sistema de cierre y elevacion electrico.



PRODUCCION BAJA
ESCALA



UTILERIA
DEPORTIVA



STAND EXHIBIDOR



PUESTO DE CONTROL
INDUSTRIA



SOLUTIONS

Discover our range of high-quality solutions. Intelligent designs.

COCINA SIN
CONTAMINACION



TAREAS DE
LABORATORIO



SALUD



MOBILIARIO SANITARIO

acero inoxidable 304L

BY MEDELINOX



MESAS Y MESADAS

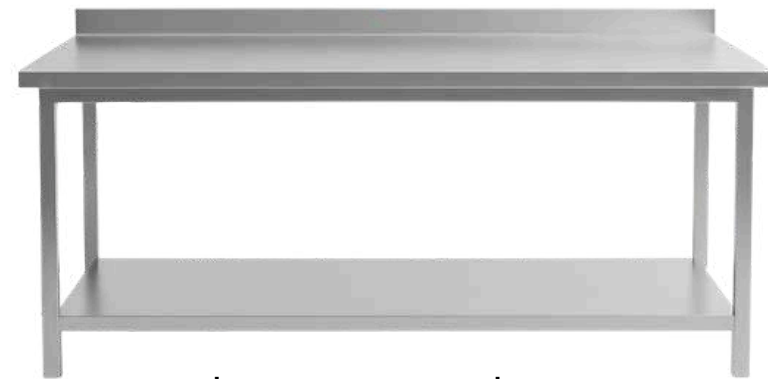

Mesada con zócalo trasero
+ estante



Mesa móvil con estante



Mesada con zócalo trasero
+ bacha + grifería + estante



Mesada con zócalo trasero
+ estante + doble estante
superior



Mesada con zócalo trasero
extendido porta utensilios +
bacha + grifería + estante
escurridor



Mesada con zócalo trasero
extendido porta utensilios +
bacha + grifería + rinser
lava copas + estante
escurridor

DETALLES

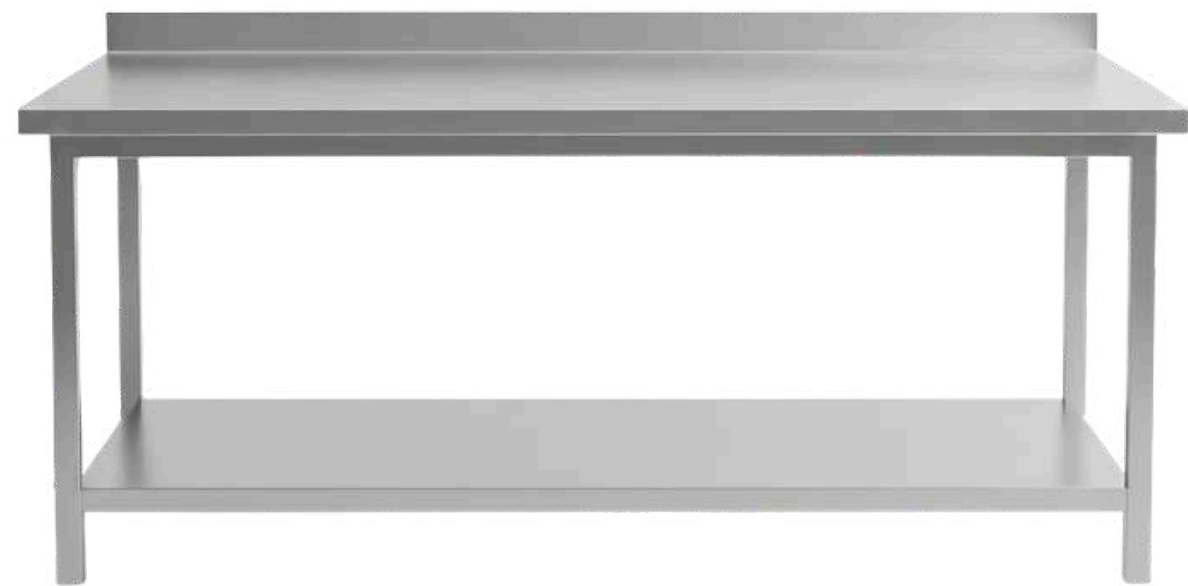

LARGOS: 0.9 / 1.4 / 1.9 /
2.4 M



0.6 M

0.9 M

- ESTRUCTURA 100% CAÑO ESTRUCTURAL 40X40 INOX. CAL. AISI 304L.-
- 100% SOLDADURA LASER.-
- CHAPA ESPESOR 1.2MM 100% INOX. CAL. AISI 304L.-
- FINAL DE ESTRUCTURA CON REGAETON DE GOMA ANTIDESLIZANTE.-
- BACHA ESTANDAR COMERCIAL: 70X40X20CM
 - **UBICACION A PEDIDO: DER/IZQ/CENTRO.-
- CANILLA MONOCOMANDO CROMADA S/DISPONIBILIDAD.-
- BANDEJA ESCURRIDORA CONFORMADA EN CHAPA PERFORADA REBATIBLE Y DESAGUE. INOX. CAL. AISI 304L.-
- RINSER LAVACOPAS EMBUTIDO 18X18X7 CM.-
- RUEDAS Ø80MM GIRATORIAS C/FRENO.-
- ALTO ZOCALO 5 CM.-
- ALTO ZOCALO EXTENDIDO 50 CM.-
- DOBLE ESTANTE SUPERIOR: 0.30 X 0.30 DE LUZ X LARGO DE MESADA.-

MOBILIARIO



Mesa lisa sin patas



Mesada con zócalo sin patas



Mesada con zócalo + bacha
+ grifería sin patas



Carro de transporte 2 a 5
estantes + ruedas: 0.60 x
0.90 / 1.40 m x 0.30 de luz
entre estante x h max. 1.90
m



Estanterías de 2 a 5 estantes:
0.30 x 0.90 / 1.40 / 1.90 /
2.90 m x 0.30 de luz entre
estante x h max. 1.90 m



RESTO BAR DESIGNS

INNOVATION BY MEDELINOX





BIENVENIDO



En este catalogo vas a conocer soluciones innovadoras y practicas de gran calidad. Te invitamos a que conozcas una moderna forma de trabajar y transformar espacios.

WELCOME



In this catalog, you'll discover innovative and practical solutions of exceptional quality. We invite you to explore a modern way of working and transforming spaces.

WORK INNOVATION

Resto - bar



Hoteleria -



House -



Discoteca -



Cocina -



WORK INNOVATION

DISEÑO Y FABRICACION DE BARRAS Y COCINAS MODULARES

Diseñamos y fabricamos barras modulares para facilitar instalaciones y brindar un espacio de trabajo que optimice la eficiencia del operario.

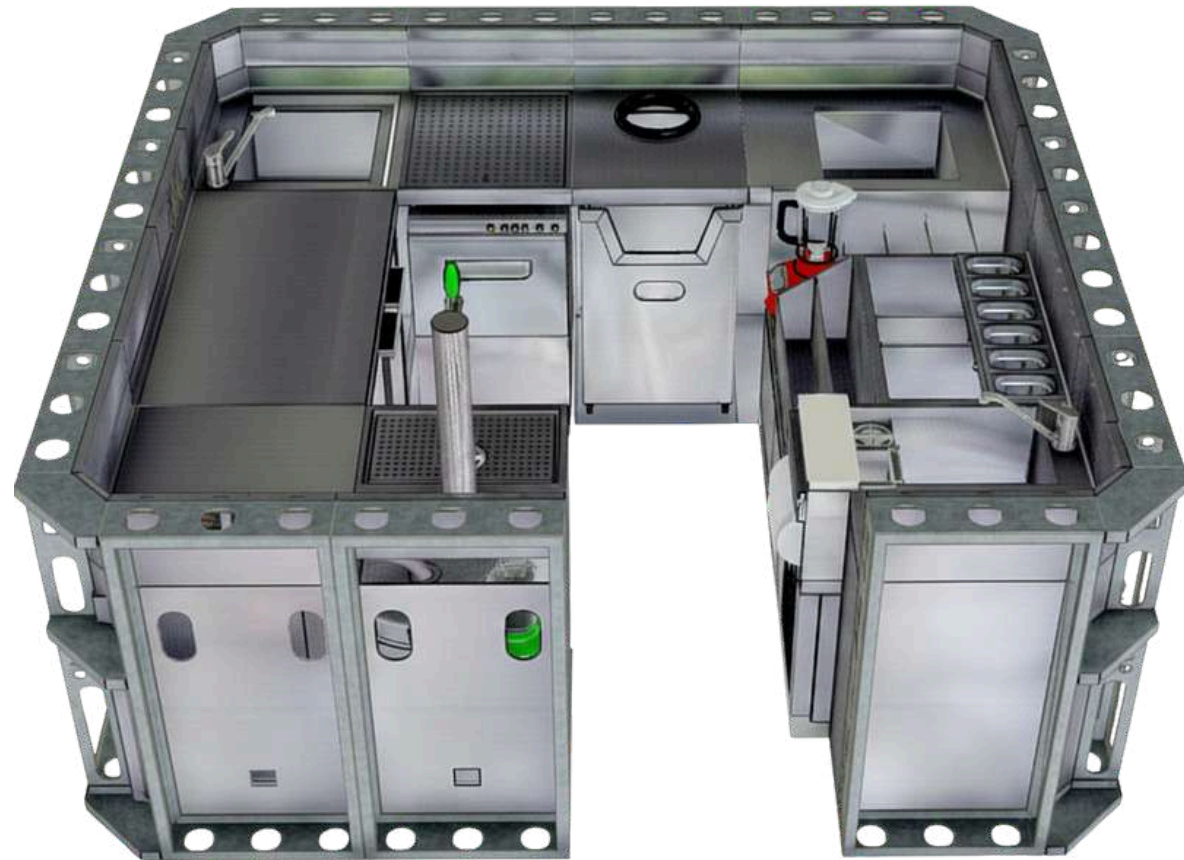

WORK INNOVATION



DESIGN AND MANUFACTURE OF MODULAR BARS AND KITCHENS

We design and manufacture modular bars to facilitate installations and provide a workspace that optimizes operator efficiency.



WORK INNOVATION



DISEÑO ERGONOMICO

Optimizar el espacio de trabajo mejora la comunicación con el cliente, disminuye tiempos de servicio y generar una experiencia única para el cliente.



ERGONOMIC DESIGN

Optimizing the workspace improves customer communication, reduces service times, and creates a unique customer experience.

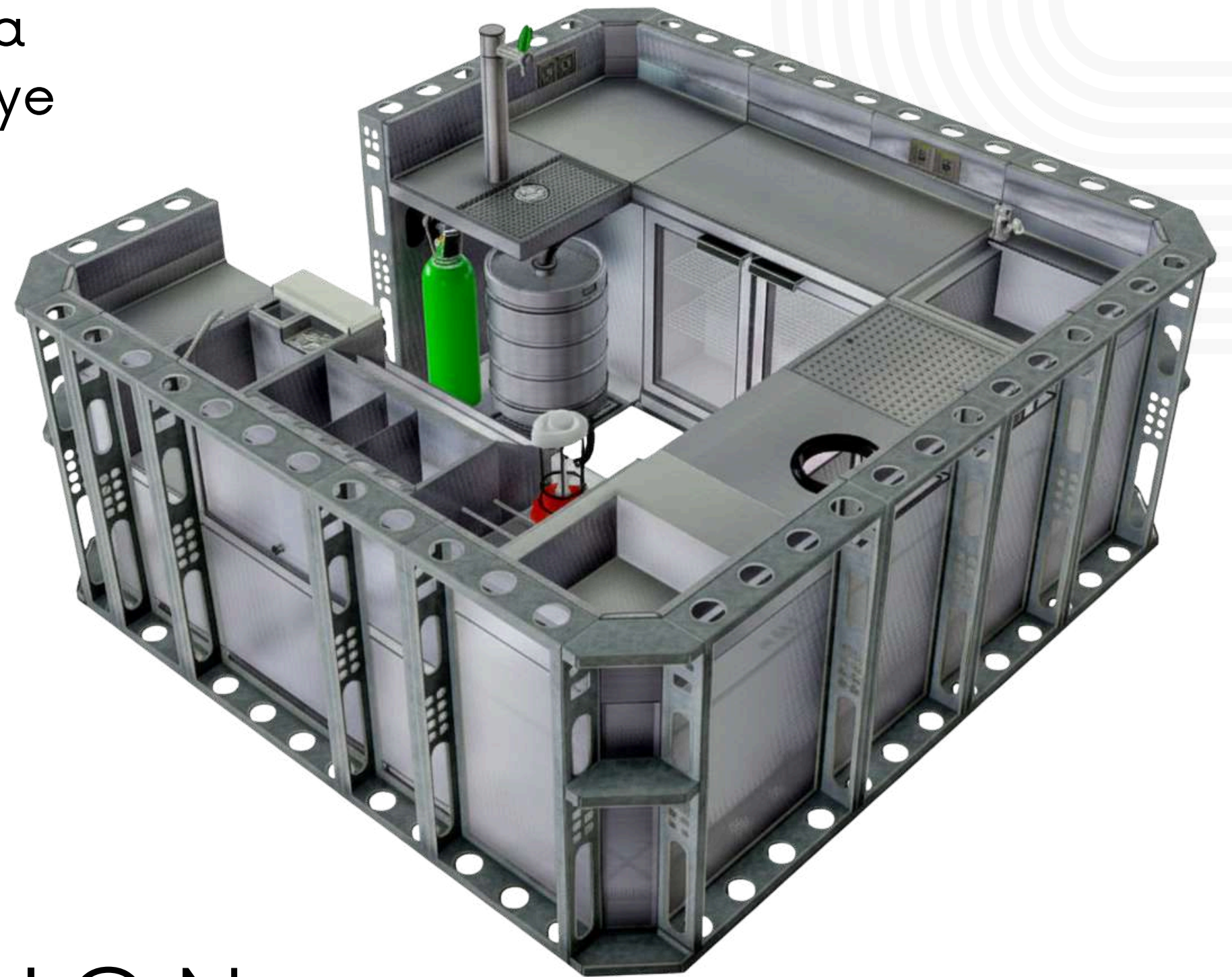

WORK INNOVATION

SISTEMA MODULAR

Nuestros diseños le permiten ahorrar gran cantidad de tiempo y dinero en conformar un excelente equipamiento para su restaurante con módulos prediseñados, ajustándose a las medidas y necesidades básicas de su negocio.



MODULAR SYSTEM

Our designs allow you to save a great deal of time and money in creating excellent equipment for your restaurant with pre-designed modules, adjusting to the measurements and basic needs of your business.

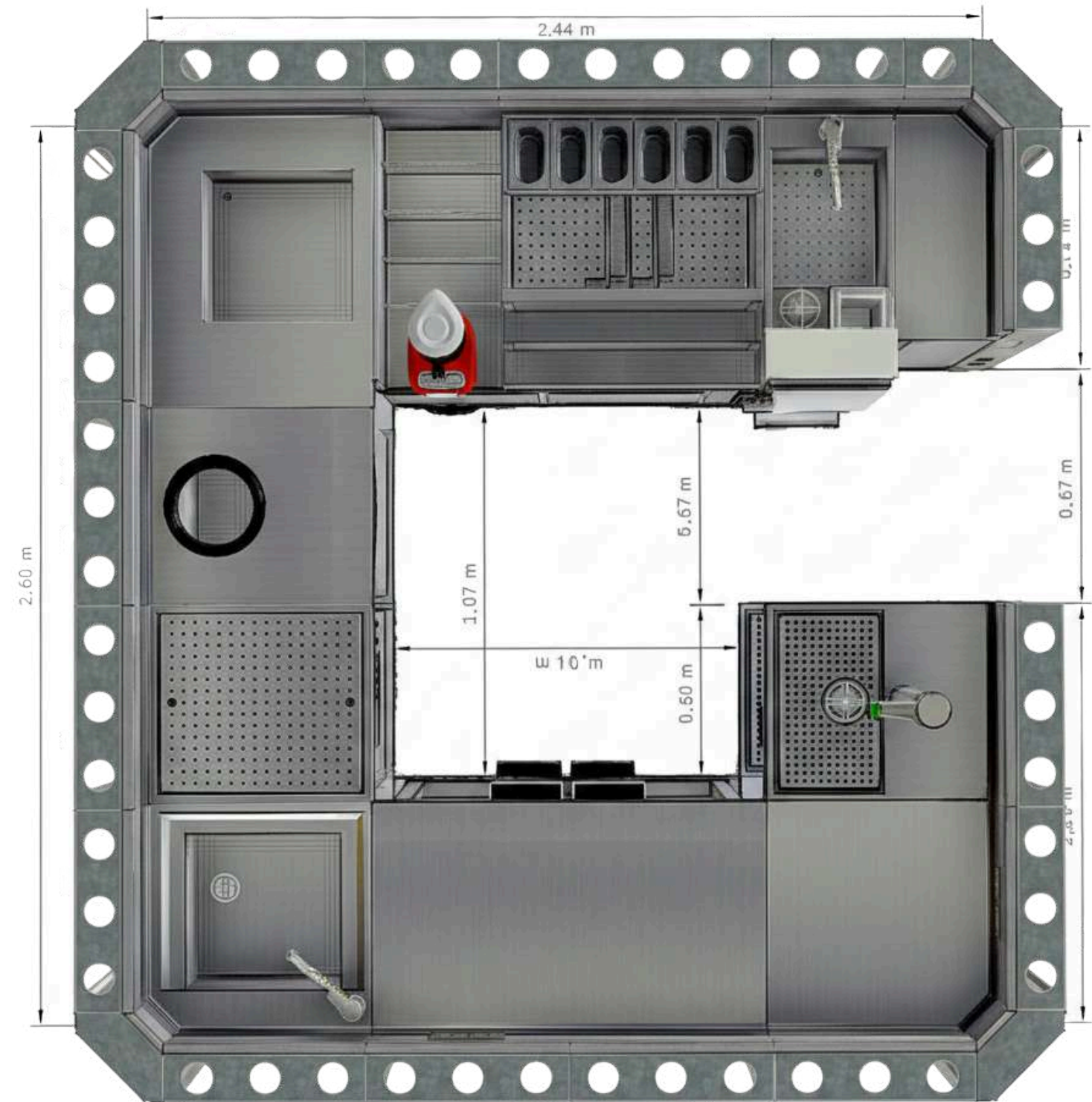

WORK INNOVATION





CONFIGURACION A MEDIDA

Nuestro equipo de diseño podrá facilitarle un modelo de la configuración de los módulos de mobiliario de acero prediseñados sobre planos de su local. Así tendrá la capacidad de valorar y visualizar la barra conformada en su cafetería, bar o restaurante.

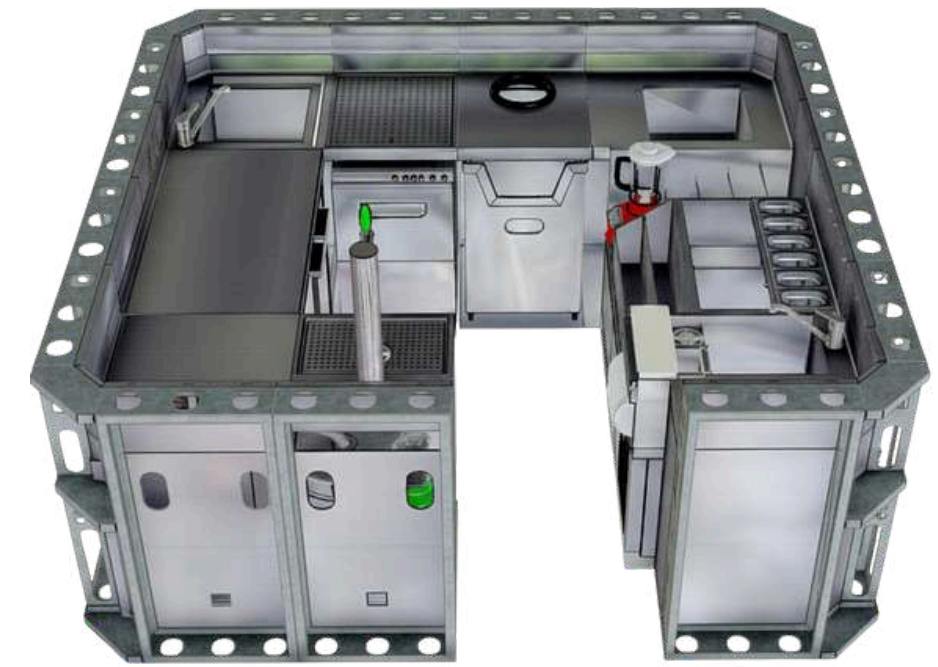

CUSTOM CONFIGURATION

Our design team can provide you with a model of the pre-designed steel furniture modules based on your premises' floor plans. This will allow you to evaluate and visualize the finished bar in your café, bar, or restaurant.



Hielo + Garnish + Speedrail

Módulo cuba de hielo 666x500mm con doble speed-rail (14 botellas), con estante almacén.



Ice + Garnish + Speedrail

Ice tank module 666x500mm with double speed-rail (14 bottles), with storage shelf.



Botellero Piramidal

Módulo pirámide de botellas
500x600mm (25 botellas), con estante
almacén.



Pyramidal Bottle Rack

Pyramid-shaped bottle module
500x600mm (25 bottles), with storage
shelf.



Cerveza Esquinero

Módulo expendio cervecera esquinera 600x600mm , con 4 entradas de conexiones de cerveza, grifo opcional.



Corner Beer Dispensing Module

Corner beer dispensing module 600x600mm, with 4 beer connection ports, optional tap.



Zona de Residuos

Módulo residuos carrito
500x600mm con agujero de
desbarace.



Waste Area

Waste cart module 500x600mm
with disposal hole.



Rejilla escurre copas

Módulo Lavavajillas
666x600mm con bandeja salva
aguas y rejilla.



Glass draining rack

Dishwasher module 666x600mm
with drip tray and rack.



Mesa de trabajo con escurridor

Módulo de trabajo con estantes de 666x600mm con bandeja salva aguas y rejilla.



Work table with drainer

Work module with shelves measuring 666x600mm, with drip tray and wire rack.



Lava copas con estante escurridor

Módulo para limpieza de copas
con estantes de 666x600mm
con bandeja salva aguas y
rejilla.



Glass washer with draining rack

Glass cleaning module with
666x600mm shelves, drip tray,
and rack.



Cocina-horno o anafe a gas 4 o 6 hornallas

Modulo a eleccion cocina con horno o anafe a gas de 4 o 6 hornallas (640/950x630mm)



Kitchen with oven or gas cooktop (4 or 6 burners)

Choice of kitchen module with oven or gas cooktop (4 or 6 burners) (640/950x630mm)



Fritera doble electrica

Módulo para freir con doble
recipiente electrico
600x600mm



Electric Double Deep Fryer

Double electric frying module,
600x600mm



Bacha de enjuague

Módulo para limpieza y enjuague. Bacha de 600 a 800mm x 400 a 500mm x 250 a 400mm (segun disponibilidad).



Rinse basin

Module for cleaning and rinsing. Basin dimensions: 600 to 800 mm x 400 to 500 mm x 250 to 400 mm (depending on availability).

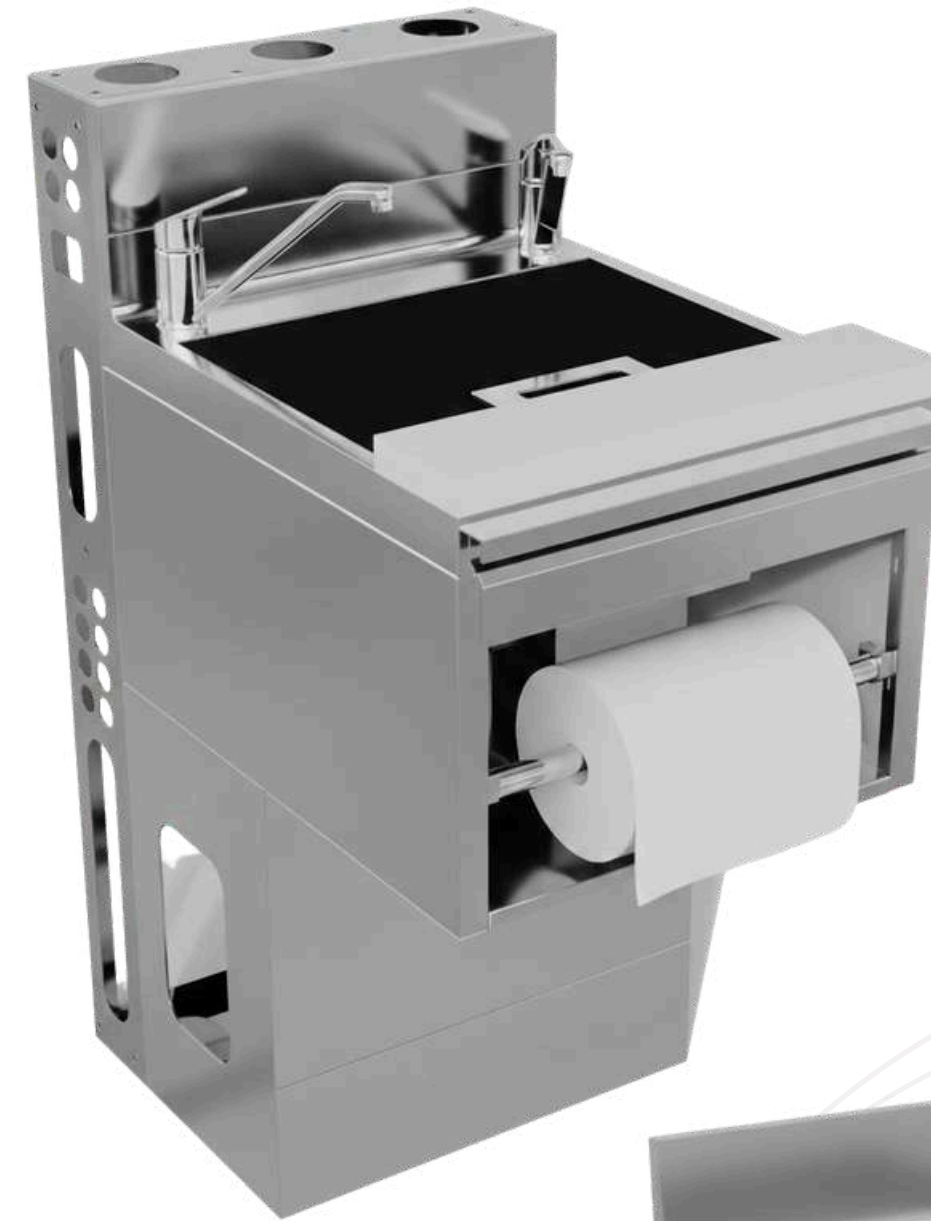

Refrigerador bajo mesada doble o simple

Módulo de refrigeración doble
con bandeja superior
900x700mm (puerta acero o
vidrio s/disponibilidad)



Double or single under-counter refrigerator

Double refrigeration module
with upper shelf 900x700mm
(steel or glass door depending
on availability)





LA INSTALACIÓN EN OBRA MÁS SENCILLA
Las distintas unidades que conforman la barra del bar se envían pre-ensambladas para reducir los tiempos de instalación y mano de obra para garantizar un acabado elegante y sin complicaciones.



FÁCIL REPARACIÓN
Los paneles exteriores extraíbles facilitan el mantenimiento en todo momento o en caso de averías con la solución más inteligente. En caso que tuviese cualquier fuga, problema eléctrico o necesidad de reemplazar o añadir algún componente.



ENVIOS PRE-MONTADO
Las distintas unidades que conforman la barra del bar se envían pre-ensambladas para reducir los tiempos de instalación y mano de obra para garantizar un acabado elegante y sin complicaciones.



SIN OBRA DE CONSTRUCCIÓN HUMEDA
Nuestro mobiliario modular para barras de acero inoxidable cuenta con perfiles de acero galvanizado sin la necesidad de paredes de construcción alrededor.





THE EASIEST ON-SITE INSTALLATION

The various units that make up the bar counter are shipped pre-assembled to reduce installation time and labor, ensuring a sleek and hassle-free finish.



EASY REPAIR

The removable exterior panels make maintenance easy at any time or in case of breakdowns, providing the smartest solution. This applies to any leaks, electrical problems, or the need to replace or add any components.



PRE-ASSEMBLED SHIPPING

The various units that make up the bar counter are shipped pre-assembled to reduce installation time and labor, ensuring a sleek and hassle-free finish.



NO WET CONSTRUCTION REQUIRED

Our modular stainless steel bar furniture features galvanized steel profiles without the need for surrounding construction walls.



NEXT STEP CONTACT US

MEDELINOX.COM

administracion@medelinox.com.ar

+54 9 3401 499068



El Trebol, Santa Fe, Argentina

FIND US ON SOCIAL MEDIA OR CONTACT US.

